

Serie Actuators

Cilindro a Cartuccia

Cartridge Cylinders
Einschraubzylinder
Vérins cartouche
Cilindros de cartucho
Cilindro Plug

Ø 6-16 mm

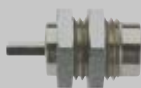

Serie CA - CAF

Pag. 18.5 - 18.7

MiniCilindri

MiniCylinders
Minizylinder
Mini-vérins
Minicilindros
Mini-cilindros

ISO 6432 - Ø 8-25 mm



Serie Mini

Pag. 18.8 - 18.20

MiniCilindri Inox

MiniCylinders Inox
Minizylinder Inox
Mini-vérins inox
Minicilindros Inox
Mini-cilindros Inox

ISO 6432 - Ø 16-25 mm



Serie Mini Inox

Pag. 18.21 - 18.25

Cilindro A95

Cilindros A95
Zylinder A95
Vérins A95
Cilindros A95
Cilindros A95

Ø 32-63 mm



Serie A95

Pag. 18.26 - 18.35

Cilindri Compatti

Compact Cylinder
Kompaktzylinder
Vérins compacts
Cilindros Compactos
Cilindros Compactos

Ø 12-100 mm



Serie Q

Pag. 18.36 - 18.48

Cilindri Corsa Breve

Short Stroke Cylinders
Kurzhubzylinder
Vérins à faible course
Cilindros Carrera Corta
Cilindros de curso Reduzido

Ø 12-100 mm

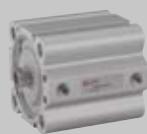

Serie B

Pag. 18.49 - 18.62

Cilindro

Cylinder
Zylinder
Vérins
Cilindros
Cilindros

ISO 15552 - Ø 32-125 mm



Serie X

Pag. 18.65 - 18.72

Cilindro

Cylinder
Zylinder
Vérins
Cilindros
Cilindros

ISO 6431 - Ø 32-320 mm



Serie E

Pag. 18.73 - 18.78

Cilindro INOX

Cylinder INOX
Zylinder INOX
Vérins INOX
Cilindros INOX
Cilindros INOX

ISO 15552 - Ø 32-125 mm



Serie V

Pag. 18.79 - 18.83

Cilindro Steli Gemellati

Twin piston rod Cylinders
Twin Kolbenstange Zylinder
Vérins à deux tiges
Cilindros de vástagos gemelos
Cilindro de haste dupla

ISO 15552 - Ø 32-100 mm



Serie NHA

Pag. 18.84 - 18.90

Cilindri Compatti

Compact Cylinder
Kompaktzylinder
Vérins compacts
Cilindros Compactos
Cilindros Compactos

ISO 21287 - Ø 20-100 mm



Serie W

Pag. 18.91 - 18.100

Cilindri Compatti

Compact Cylinder
Kompaktzylinder
Vérins compacts
Cilindros Compactos
Cilindros Compactos

Ø 125-250 mm



Serie P

Pag. 18.101 - 18.104

Accessori per Cilindri

Accessories for Cylinders
Befestigungselemente für Zylinder
Accessoires pour Vérins
Accesorios para Cilindros
Accesorios para Cilindros

ISO 6431 - ISO 15552 - ISO 21287



Pag. 18.105 - 18.116

Unità di Guida

Guide Units
Führungseinheiten
Unités de guidage
Unidades de Guiado
Guia para cilindros

ISO 15552 - Ø 12-25 mm
ISO 6431 VDMA - Ø 32-100 mm



Pag. 18.117 - 18.126

Cilindri con guida integrata

Double-acting magnetic twin-guide cylinders
Zylinder mit integrierter Führung
Vérins avec guide intégré
Cilindros con vástagos paralelos
Cilindros com haste dupla



Serie CG01 - CG02

Pag. 18.127 - 18.137

Cilindro con tavola di scorrimento

Slide cylinder
Zylinder mit Schiebetisch
Vérin avec table linéaire
Cilindros guiados con mesa de deslizamiento
Cilindros com mesa deslizante

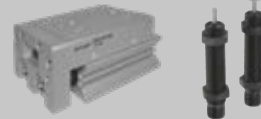

Serie CG04

Pag. 18.138 - 18.149

SHOCK
ABSORBER

Cilindri Senza Stelo

Rodless Cylinder
Kolbenstangenlose Zylinder
Vérins Sans Tige
Cilindro Neumático sin vástago
Cilindro Pneumático sem haste

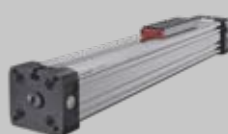

Serie R

Pag. 18.151 - 18.173

Cilindri Rotanti

Rotary cylinders ISO 15552
Drehzylinder ISO 15552
Vérins rotatifs ISO 15552
Cilindros rotativos ISO 15552
Cilindros rotativos ISO 15552



Serie XR - RT01 - RT03S

Pag. 18.174 - 18.192

Pinze pneumatiche

Pneumatic gripper
Pneumatische greifer
Pince pneumatique
Pinza neumática
Garra neumática



Serie GR01F/GR02F/GR03F GR04F/GR05F

Pag. 18.193 - 18.218

Sensori

Sensors
Sensoren
Capteurs
Sensores
Sensores

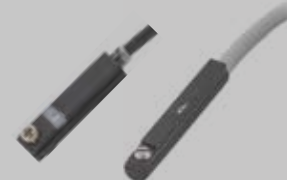

Pag. 18.220 - 18.231

ATTUATORI PNEUMATICI

PNEUMATIC ACTUATORS

PNEUMATISCHE ANTRIEBE

ACTIONNEURS PNEUMATIQUES

ACTUADORES NEUMÁTICOS

ATUADORES PNEUMÁTICOS



Serie Actuators

Le gamme di attuatori pneumatici Aignep, sono il frutto dell'esperienza produttiva e dei massicci investimenti fatti in ricerca e sviluppo.

Il costante studio delle soluzioni, dei materiali e tecnologie, legate alle esigenze reali e crescenti dei clienti in tutto il mondo consentono ad Aignep di poter offrire soluzioni vincenti ed altamente performanti.

A semplice o doppio effetto, in alluminio o in acciaio inox, nel rispetto di tutte le normative internazionali la gamma proposta consente di affrontare ogni applicazione, dalle più semplici alle più complesse.

Cilindri ATEX:

- **Ex** II 2 GD c T6 -20°C<Tamb<80°C

Principali vantaggi

- Conformità alle norme di riferimento internazionali
- Tenute in PU alta scorrevolezza e durata
- 20 tipologie differenti, lineari, senza stelo, guidati
- Versioni alta temperatura e basso attrito
- Differenti materiali costruttivi
- Versioni Custom e speciali
- ATEX di serie
- Disponibilità immediata

Applicazioni

- Automazione Pneumatica, Robotica e manipolazione
- Automotive Process
- Industria tessile, imballaggio, farmaceutica, pesante
- Food Process
- ATEX Zone

Pneumatic actuators is the result of the manufacturing experience of Aignep and major investements toward innovation.

The continuous research for solutions, materials and technologies satisfy the most demanding and specific needs.

Large range of standards: cartridge, compact, mini ISO 6432, ISO 15552, ISO 21287, large bore, rotary etc.

Mainly available in single or double acting, magnetic, cushion, double rods, etc..

Actuators ATEX:

- **Ex** II 2 GD c T6 -20°C<Tamb<80°C

Main advantages

- International Standards Conformity
- PU seal low fiction and long lasting
- Wide range
- High temperature version on demand
- Wide selection of materials
- Customized or Special version
- ATEX certified
- Immediate delivery

Applications

- Pneumatic Automation, Robotics, Handling
- Automotive Process
- Textile, Packaging, Heavy Duty
- Food Process
- ATEX Zone

Die pneumatischen Antriebe von Aignep sind das Ergebnis grosser Erfahrung in der Herstellung und hohen Investitionen in Forschung und Entwicklung.

Die kontinuierliche Forschung nach Lösungen, Materialien und Technologien bietet Antworten auf die meistgeforderten und spezifischen Bedürfnisse.

Grosse Standard-Auswahl: Patrone, kompakt, Mini ISO 6432, ISO 15552, ISO 21287, grosse Bohrung, Drehbar etc. Hauptsächlich einfach- oder doppelwirkend, magnetisch, Dämpfung, durchgehender Kolben, etc..

Antriebe ATEX:

- **Ex** II 2 GD c T6 -20°C<Tamb<80°C

Hauptvorteile

- Konform mit internationalen Standards
- PU-Dichtung glatt und langlebig
- Grosse Auswahl
- Hochtemperatursausführung auf Anfrage
- Grosse Auswahl verschiedener Materialien
- Kunden- oder Sonderausführungen
- ATEX zertifiziert
- Sofortige Lieferung

Anwendungen

- Pneumatische Automation, Robotik, Handling
- Automobil Prozess
- Textil-, Verpackungs-, Schwerlast-Industrie
- Lebensmittel Prozess
- ATEX Bereich



FR

La gamme des vérins pneumatiques est le fruit de l'expérience d'Aignep tant coté fabrication qu'innovation.

Toujours soucieux de développer et d'apporter des solutions pour répondre aux besoins les plus exigeants et spécifiques. Large gamme de produits standards: vérins cartouche, compact, mini suivant ISO 6432, ISO 15552, ISO 21287 etc.

En simple ou double effet, en aluminium ou en acier inoxydable, en conformité avec toutes les normes internationales, permet de faire face à toutes les utilisations, de la plus simple à la plus complexe.

Vérins ATEX:

- **Ex** II 2 GD c T6 -20°C<Tamb<80°C

Principaux avantages

- Conformes aux normes internationales
- Joint PU faible friction et longue durée de vie
- Large gamme
- Version haute température sur demande
- Large choix de matériaux
- Versions spéciales sur demande
- Certifié ATEX
- Livraison immédiate

Applications

- Automatisation Pneumatiques, Robotique, Manutention
- Process Automobile
- Textile, Heavy Duty
- Process alimentaire
- Zone ATEX

ES

La gama de actuadores neumáticos Aignep, son el fruto de la experiencia productiva y de las masivas inversiones realizadas en investigación y desarrollo.

El constante estudio de las soluciones, materiales y tecnologías, combinadas con las exigencias reales y crecientes de los clientes de todo el mundo permiten a Aignep de poder ofrecer soluciones ganadoras y de alto rendimiento.

De simple y doble efecto, en aluminio o en acero inox, respetando todas las normativas internacionales la gama propuesta permite afrontar cada aplicación, de las más simples a las más complejas.

Actuadores ATEX:

- **Ex** II 2 GD c T6 -20°C<Tamb<80°C

Principales ventajas

- Conformidad a las normas de referencia internacional
- Juntas en PU baja fricción y alta duración
- 20 tipologías diferentes, lineales, sin vástago, guiados
- Versiones para alta temperatura y bajo rozamiento
- Diferentes materiales constructivos
- Versiones Standard y especiales
- ATEX de serie
- Disponibilidad inmediata

Aplicaciones

- Automatización neumática, Robótica y manipulación
- Procesos de automoción
- Industria textil, embalaje, farmacéutica y pesada
- Alimentaria
- Zona ATEX

PT

Os cilindros pneumáticos são o resultado da experiência de produção da Aignep, além de serem seu maior investimento em busca da inovação.

As contínuas pesquisas em soluções, materiais e tecnologias satisfazem as mais severas e específicas necessidades de automação. Um grande range de modelos: cilindros cartucho, compactos, mini ISO 6432, ISO 15552, ISO 21287, large bore, rotativos etc.

Principalmente disponíveis em simples ou dupla ação, magnético, com amortecimento pneumático, haste passante, etc.

Cilindros ATEX:

- **Ex** II 2 GD c T6 -20°C<Tamb<80°C

Principais vantagens

- Conformidade com Padrões Internacionais
- Alta durabilidade e baixo atrito nas vedações de PU
- Grande range de opções
- Versões para Altas Temperaturas sob demanda
- Grande variação de materiais
- Versões customizadas ou especiais
- Certificação ATEX padrão
- Entrega imediata

Aplicações

- Automação Pneumática, Robótica, Manipulação
- Processos Automotivos
- Têxtil, Embalagem, Heavy Duty
- Processos Alimentícios
- Aprovação ATEX

SERIE CG01 - CILINDRI CON GUIDA INTEGRATA

DOUBLE-ACTING MAGNETIC TWIN-GUIDE CYLINDERS
 ZYLINDER MIT INTEGRIERTER FÜHRUNG
 VÉRINS AVEC GUIDE INTÉGRÉ
 CILINDROS CON VÁSTAGOS PARALELOS DOBLE EFECTO MAGNETICO
 CILINDRO DUPLA AÇÃO MAGNÉTICO COM GUIA DUPLA



CARATTERISTICHE TECNICHE
 TECHNICAL CHARACTERISTICS
 TECHNISCHE ANGABEN
 CARACTÉRISTIQUES TECHNIQUES
 CARACTERÍSTICAS TÉCNICAS
 CARACTERÍSTICAS TÉCNICAS



1907/2006
 REACH

2011/65/CE
 RoHS

Materiali	IT	Materials	GB	Materialien	DE
<ul style="list-style-type: none"> Corpo: Lega alluminio Piastra: Acciaio Stelo: Ø 12+20 acciaio inox Ø 25+63 Acciaio Magnete: Plastroferrite Guarnizioni: NBR Ammortizzatore: NBR 		<ul style="list-style-type: none"> Body: Aluminum alloy Plate: Carbon Steel Piston rod: Ø 12+20 Stainless steel Ø 25+63 Carbon Steel Magnet: Plastroferrite NBR seals Cushion: NBR 		<ul style="list-style-type: none"> Körper: Aluminium Legierung Platte: Stahl Kolbenstange: R 12+20 Edelstahl R 25+63 Stahl Magnet: Plastroferrit Dichtungen: NBR Stossdämpfer: NBR 	
Matériaux	FR	Materiales	ES	Materiais	PT
<ul style="list-style-type: none"> Corps : Alliage d'aluminium Plaque : Acier Tige : Ø 12+20 acier inox Ø 25+63 Acier Aimant : Plastroferrite Joints : NBR Amortissement : NBR 		<ul style="list-style-type: none"> Cuerpo: Aleación de aluminio Placa: Acero Vástago: Ø 12+20 acero inox Ø 25+63 Acero Magnete: Plastroferrita Juntas: NBR Amortiguación: NBR 		<ul style="list-style-type: none"> Corpo: Liga de alumínio Placa: Aço Haste: Ø 12+20 aço inox Ø 25+63 Aço Magnético: Plastroferrite Vedações: NBR Amortecimento: NBR 	



Pressioni

Pressures
 Druckbereich
 Pressions
 Presiones
 Pressões

1 bar (0.1 MPa)

10 bar (1 MPa)



Temperature

Temperatures
 Temperatures
 Temperatur
 Températures
 Temperaturas
 Temperaturas

-5 °C (No freezing)

+ 60 °C



Fluidi compatibili

Aria (Lubrificazione non necessaria).

Fluids
 Air (Lubrication not necessary).

Geeignete Medien
 Luft (Schmierung nicht erforderlich).

Fluides compatibles
 Air (Lubrification pas nécessaire).

Fluidos compatibles
 Aire (Lubrificación no necesaria).

Fluidos compatíveis
 Ar (Lubrificação não necessária).



Alesaggi

Bores
 Durchmesser
 Diamètres
 Diámetros
 Diâmetros

12-16-20-25-32-40-50-63 mm



Range velocità

Speed range
 Verfügbarer Geschwindigkeitsbereich
 Plage de vitesse disponible
 Rango velocidad
 Range de velocidades

50 mm/sec
500 mm/sec



Peso cilindro

Cylinder Weight

Zylinder Gewicht

Poids du vérin

Peso Cilindro

Peso do Cilindro

Ø	Standard stroke (mm)	
	Basic weight	Stroke 5 mm
12	191	21
16	283	28
20	450	45
25	670	63
32	1.210	90
40	1.474	88
50	2.540	140
63	3.345	157

(Unit: g)



Sensori consigliati

Sensors recommended

Empfohlene Sensoren

Capteurs recommandés

Sensores recomendados

Sensores aconselhados

DC 01 RM8

DC 01 R2M

DC 03 PM8

DC 03 P2M

DC 04 PM8

DC 04 P2M



Tabella dei codici di ordinazione

Ordering codes

Bestellschlüssel

Code de commande

Tabla de codificación para pedidos

Tabela de codificação para compra

SERIE	Ø mm	Corsa Stroke Hub Course Carrera Curso mm
-------	---------	--

C G 0 1

0 1 2

0 0 1 0

012
016
020
025
030
032
040
050
063

0010
0020
0025
0030
0040
0050
0075
0100
0125
0150
0175
0200
0250
0300
0350
0400

A richiesta corse intermedie o superiori.
Intermediate or higher strokes are available upon request.
Auf Anfrage Zwischenhübe.
Autres courses sur demande.
Bajo demanda carreras intermedias o superiores.
Cursos intermedíarios ou superiores sob encomenda.

Ø mm	Stroke (mm)															
	10	20	25	30	40	50	75	100	125	150	175	200	250	300	350	400
12	▲	▲		▲	▲	▲	▲	▲	▲	▲	▲	▲	▲			
16	▲	▲		▲	▲	▲	▲	▲	▲	▲	▲	▲	▲			
20		▲		▲	▲	▲	▲	▲	▲	▲	▲	▲	▲		▲	▲
25		▲		▲	▲	▲	▲	▲	▲	▲	▲	▲	▲	▲	▲	▲
32			▲			▲	▲	▲	▲	▲	▲	▲	▲	▲	▲	▲
40			▲			▲	▲	▲								
50			▲			▲	▲	▲								
63			▲			▲	▲	▲								

CG01 Ø 12 ÷ Ø 32

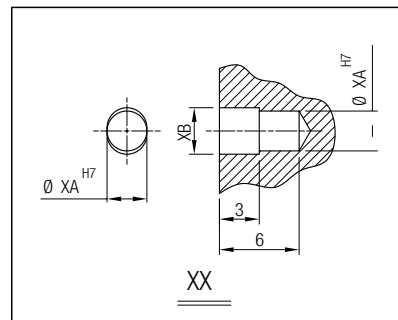
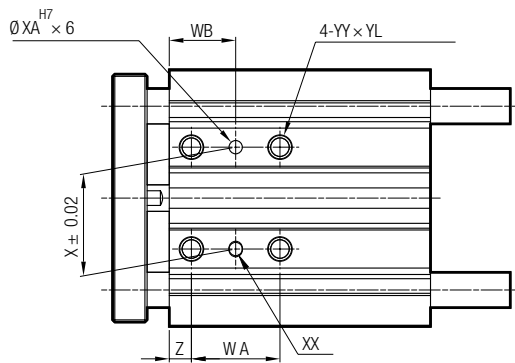

Back side

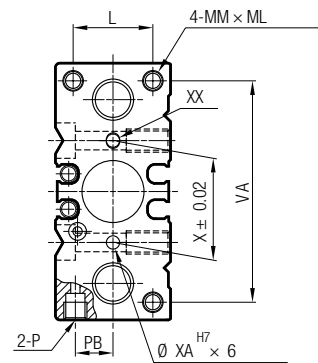
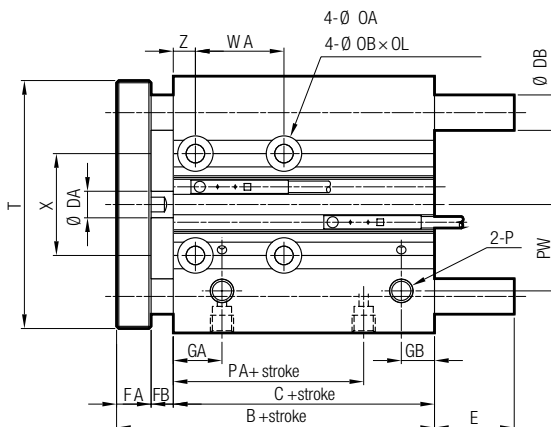
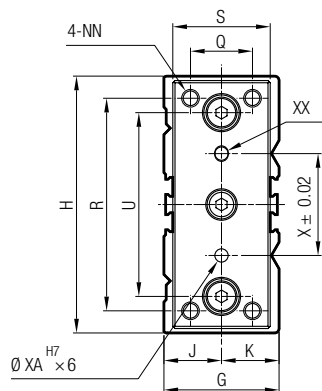

Ø	B	C	DA	DB	FA	FB	G	GA	GB	H	J	K	L	MM	ML	NN	OA	OB	OL
12	42	29	6	8	8	5	26	11	15*	58	13	13	18	M4 x 0,7	10	M4 x 0,7	4,3	8,0	4,5
16	46	33	8	10	8	5	30	11	18**	64	15	15	22	M5 x 0,8	12	M5 x 0,8	4,3	8,0	4,5
20	53	37	10	12	10	6	36	10,5	8,5	85	17	19	24	M5 x 0,8	13	M5 x 0,8	5,2	9,5	5,5
25	53,5	37,5	12	16	10	6	42	11,5	9	96	21	21	30	M6 x 1,0	15	M6 x 1,0	5,2	9,5	5,5
32	59,5	37,5	16	20	12	10	51	12,5	9	116	26	25	34	M8 x 1,25	20	M8 x 1,25	6,6	11,0	7,5

Ø	P	PA	PB	PW	Q	R	S	T	U	VA	X	XA	XB	YY	YL	Z	E		
																	st. 10-50	st. 51 - 100	st. 100+
12	M5 x 0,8	14	8,5	18	14	48	22	56	41,5	50	23	3	3,5	M5 x 0,8	10	5	-	18,5	43
16	M5 x 0,8	15	10,0	19	16	54	25	62	46	56	24	3	3,5	M5 x 0,8	10	5	-	18,5	49
20	G 1/8	12,5	11,5	25	18	70	30	81	55	72	28	3	3,5	M6 x 1,0	12	17	-	31,5	69
25	G 1/8	12,5	13,5	28,5	26	78	38	91	65	82	34	4	4,5	M6 x 1,0	12	17	-	31,5	68,5
32	G 1/8	7	16,0	34	30	96	44	110	80	98	42	4	4,5	M8 x 1,25	16	21	37,5	52,5	80,5

Ø	WA					WB				
	~39st	40~100st	125~200st	201~300st	301st~	20~39st	40~100st	125~200st	201~300st	301st
12	20	40	110	200	-	15	25	60	105	-
16	24	44	110	200	-	17	27	60	105	-
20	24	44	120	200	300	29	39	77	117	167
25	24	44	120	200	300	29	39	77	117	167
32	24	48	124	200	300	33	45	83	121	171

* Quando la lunghezza della corsa è pari a 19mm o inferiore, GB=7,5mm
 When stroke length is equal to 19 mm or less, GB=7,5 mm
 Wenn Hublänge gleich 19 mm oder weniger, GB=7,5 mm
 Lorsque la longueur de la course est égale ou inférieure à 19mm, GB=7,5mm
 Cuando la longitud de la carrera es igual a 19 mm o menor, GB=7,5 mm
 Quando o curso do cilindro é igual ou inferior a 19mm, GB=7,5mm

** Quando la lunghezza della corsa è pari a 19mm o inferiore, GB=9mm
 When stroke length is equal to 19 mm or less, GB=9 mm
 Wenn Hublänge gleich 19 mm oder weniger, GB=9mm
 Lorsque la longueur de la course est égale ou inférieure à 19mm, GB=9mm
 Cuando la longitud de la carrera es igual a 19 mm o menor, GB=9 mm
 Quando o curso do cilindro é igual ou inferior a 19mm, GB= 9mm

CG01 Ø 40 ÷ Ø 63

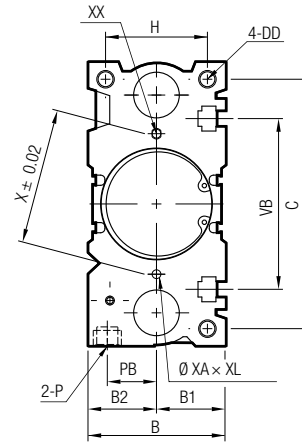
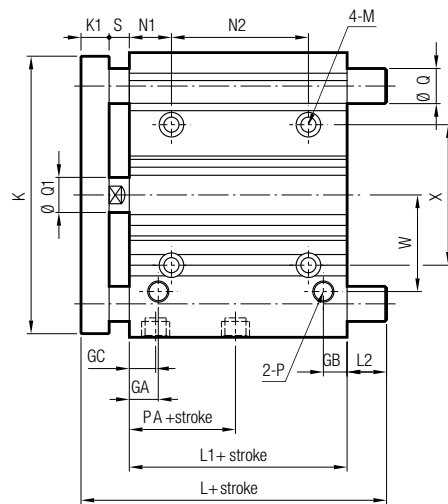
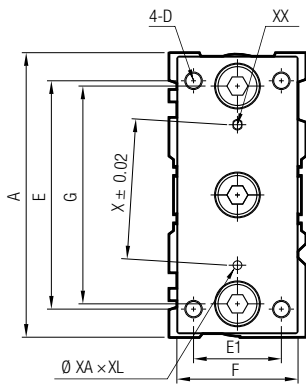
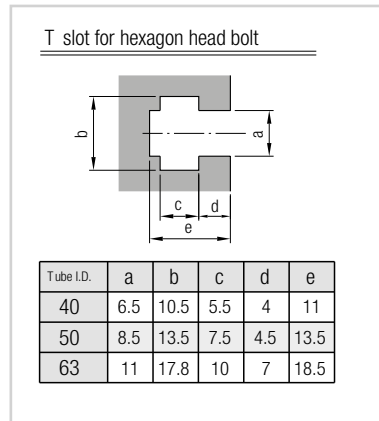
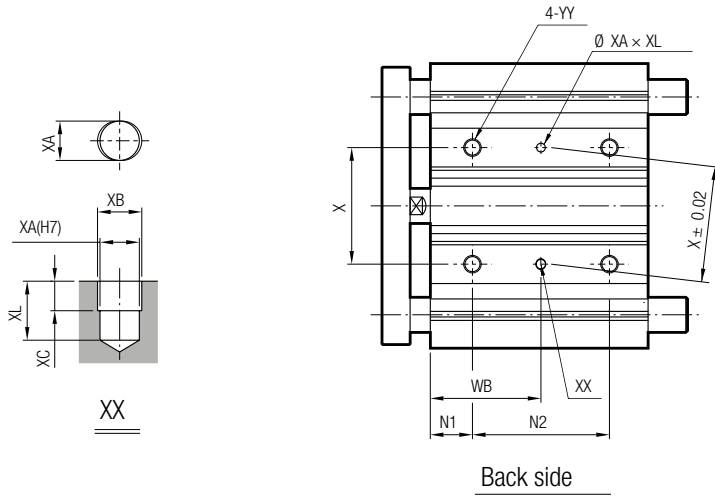

Ø	A	B	B1	B2	C	D	DD	E	E1	F	G	GA	GB	GC	H	K	K1	L1	M
40	120	54	27	27	106	M8x1,25	M8x1,25x20	104	30	44	86	14	10	14	40	118	12	44	ø6,6 - ø11x7,5
50	148	64	32	32	130	M10x1,5	M10x1,5x22	130	40	60	110	14	11	12	46	146	16	44	ø8,6 - ø14x9
63	162	78	39	39	142	M10x1,5	M10x1,5x22	130	50	70	124	16,5	13,5	16,5	58	158	16	49	ø8,6 - ø14x9

Ø	N1	P	PA	PB	Q1	S	VB	W	X	XA ^{H7}	XB	XC	XL	YY	N2			WB		
															25st	50-75-100 st	100st~	25st	50-75-100 st	100st~
40	22	G 1/8	13	18	16	10	72	38	50	4	4,5	3	6	M8x1,25x16	24	48	124	34	46	84
50	24	G 1/4	9	21,5	20	12	92	47	66	5	6	4	8	M10x1,5x20	24	48	124	36	48	86
63	24	G 1/4	14	28	20	12	110	55	80	5	6	4	8	M10x1,5x20	28	52	128	38	50	88

Ø	L		L2		Q
	25-50st	50st~	25-50st	50st~	
40	97	102	31	36	ø20
50	106,5	118	34,5	46	ø25
63	106,5	118	29,5	41	ø25

FORZE E CONSUMI

FORCES AND CONSUMPTIONS

KRÄFTE UND LUFTVERBRAUCH

FORCES ET CONSOMMATIONS D'AIR

FUERZAS Y CONSUMOS

FORÇAS E CONSUMOS

Forze di spinta e tiro - Thrust and traction forces - Schub-und zugkräfte - Force de poussée et de traction - Fuerza de empuje y tracción - Força de avanço e recuo.

Ø Cilindro Cylinder Zylinder Vérins Cilindro Cilindro	Ø Stelo Rod Stange Tige Vástago Haste	Superficie spinta Pushing surface Schubfläche Surface de poussée Superficie de empuje Área de avanço	Superficie trazione Traction surface Zugfläche Surface de traction Superficie de tracción Área de retorno	Pressione di lavoro Operating pressure Betriebsdruck Pression de service Presión de trabajo Pressão de operação									
				bar									
mm	mm	mm ²	mm ²	1	2	3	4	5	6	7	8	9	10
				Forza sviluppata Output force Zylinderkraft Force du vérin Fuerza desarrollada Força desenvolvida N									
12	6	113,04	84,78	S = 10	20	30	40	50	59,9	69,9	79,8	89,8	99,8
				T = 7,5	15	22,5	30	37,5	44,9	52,4	59,9	67,4	74,9
16	8	200,96	150,72	S = 17,7	35,5	53	71	88,7	106,5	124	141,9	159,7	177,4
				T = 13,3	26,6	39,9	53,2	66,5	79,8	93	106,5	119,7	133
20	10	314,00	235,50	S = 27,7	55,4	83,1	110,9	138,6	166,3	194	221,8	249,5	277,23
				T = 20,8	41,6	62,4	83,2	104	124,8	145,5	166,3	187,1	207,9
25	12	490,62	377,58	S = 43,3	86,6	130	173,3	216,6	259,9	303,2	346,5	389,8	433,1
				T = 33,3	66,7	100	133,3	166,7	200	233,3	266,7	300	333,4
32	16	803,84	602,88	S = 71	141,9	212,9	283,8	354,9	425,8	496,8	567,8	638,7	709,7
				T = 53,2	106,5	159,7	212,9	266,1	319,4	372,6	425,8	479	532,2
40	16	1256,00	1055,04	S = 110,9	221,8	332,6	443,5	554,5	665,4	776,2	887,1	998	1108,9
				T = 93,1	186,3	279,4	372,6	465,7	558,9	652	745,2	838,3	931,5
50	20	1962,50	1648,50	S = 173,3	346,5	519,8	693	866,3	1039,6	1212,9	1386,1	1559,4	1732,7
				T = 145,5	291	436,6	582,1	727,7	873,2	1018,8	1164,4	1310	1455,5
63	20	3115,66	2801,66	S = 275,1	550,1	825,2	1100,3	1375,4	1650,5	1925,6	2200,6	2475,7	2750,8
				T = 247,4	494,7	742	989,4	1236,8	1484,1	1731,5	1978,9	2226,2	2473,6

S Spinta - Thrust - Schub - Poussée - Empuje - Avanço

T Trazione - Traction - Zugkraft - Tracción - Tracción - Recuo

Consumi cilindro - Cylinder air consumption - Zylinder Luftverbrauch - Consommation d'air des vérins - Consumo cilindro - Consumo de ar do cilindro.

Ø Cilindro Cylinder Zylinder Vérins Cilindro Cilindro	Ø Stelo Rod Stange Tige Vástago Haste	Superficie spinta Pushing surface Schubfläche Surface de poussée Superficie de empuje Área de avanço	Superficie trazione Traction surface Zugfläche Surface de traction Superficie de tracción Área de retorno	Pressione di lavoro Operating pressure Betriebsdruck Pression de service Presión de trabajo Pressão de operação									
				bar									
mm	mm	mm ²	mm ²	1	2	3	4	5	6	7	8	9	10
				Consumo aria per ogni 10 mm di corsa Air consumption for each 10 mm of stroke Luftverbrauch pro 10 mm Hub Consommation d'air par 10 mm de course Consumo aire para cada 10 mm de carrera Consumo de ar para cada 10 mm de curso NL									
12	6	113,04	84,78	S = 0,00226	0,00452	0,00678	0,00904	0,01130	0,01356	0,01583	0,01809	0,02035	0,02261
				T = 0,00170	0,00339	0,00509	0,00678	0,00848	0,01017	0,01187	0,01356	0,01526	0,01696
16	8	200,96	150,72	S = 0,00402	0,00804	0,01206	0,01608	0,02010	0,02412	0,02813	0,03215	0,03617	0,04019
				T = 0,00301	0,00603	0,00904	0,01206	0,01507	0,01809	0,02110	0,02412	0,02713	0,03014
20	10	314,00	235,50	S = 0,00628	0,01256	0,01884	0,02512	0,03140	0,03768	0,04396	0,05024	0,05652	0,06280
				T = 0,00471	0,00942	0,01413	0,01884	0,02355	0,02826	0,03297	0,03768	0,04239	0,04710
25	12	490,62	377,58	S = 0,00981	0,01963	0,02944	0,03925	0,04906	0,05888	0,06869	0,07850	0,08831	0,09813
				T = 0,00755	0,01510	0,02266	0,03021	0,03776	0,04531	0,05286	0,06041	0,06797	0,07552
32	16	803,84	602,88	S = 0,01608	0,03215	0,04823	0,06431	0,08038	0,09646	0,11254	0,12861	0,14469	0,16077
				T = 0,01206	0,02412	0,03617	0,04823	0,06029	0,07235	0,08440	0,09646	0,10852	0,12058
40	16	1256,00	1055,04	S = 0,02512	0,05024	0,07536	0,10048	0,12560	0,15072	0,17584	0,20096	0,22608	0,25120
				T = 0,02110	0,04220	0,06330	0,08440	0,10550	0,12660	0,14771	0,16881	0,18991	0,21101
50	20	1962,50	1648,50	S = 0,03925	0,07850	0,11775	0,15700	0,19625	0,23550	0,27475	0,31400	0,35325	0,39250
				T = 0,03297	0,06594	0,09891	0,13188	0,16485	0,19782	0,23079	0,26376	0,29673	0,32970
63	20	3115,66	2801,66	S = 0,06231	0,12463	0,18694	0,24925	0,31157	0,37388	0,43619	0,49851	0,56082	0,62313
				T = 0,05603	0,11207	0,16810	0,22413	0,28017	0,33620	0,39223	0,44827	0,50430	0,56033

S Spinta - Thrust - Schub - Poussée - Empuje - Avanço

T Trazione - Traction - Zugkraft - Tracción - Tracción - Recuo

CARICO MASSIMO LATERALE AMMISSIBILE DI LAVORO

ALLOWABLE LATERAL LOAD

MAXIMAL ZULAESSIGE HORIZONTALEN KRAEFTE

CHARGE MAXIMALE LATERALE DE TRAVAIL ADMISSIBLE

CARGA MÁXIMA LATERAL ADMISIBILE DE TRABAJO

CARGA MÁXIMA LATERAL ADMISSÍVEL

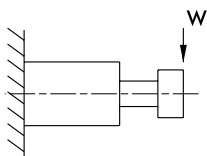

Ø	Stroke (mm)															
	10	20	25	30	40	50	75	100	125	150	175	200	250	300	350	400
12	31	24	-	19	16	13	37	31	15	13	12	10	9	-	-	-
16	50	39	-	32	27	24	54	45	27	24	21	19	16	-	-	-
20	-	51	-	44	39	35	54	46	74	66	59	54	28	24	21	19
25	-	68	-	59	52	46	72	61	98	88	79	72	53	46	41	37
32	-	-	165	-	-	129	106	90	138	123	111	101	88	77	68	61

(Unit: N)

COPPIA MASSIMA AMMISSIBILE DI ROTAZIONE

ALLOWABLE ROTATING TORQUE

MAXIMAL ZULAESSIGE ROTATIONS KRÄEFTE

COUPLE MAXIMUM DE ROTATION ADMISSIBLE

PAR DE ROTACIÓN MÁXIMO ADMISIBILE

TORQUE DE ROTAÇÃO ADMISSÍVEL

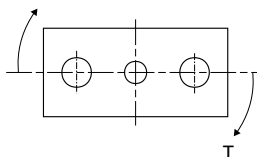

Ø	Stroke (mm)															
	10	20	25	30	40	50	75	100	125	150	175	200	250	300	350	400
12	0,64	0,48	-	0,39	0,32	0,28	0,75	0,63	0,15	0,13	0,12	0,11	0,09	-	-	-
16	1,14	0,9	-	0,74	0,63	0,55	1,23	1,04	0,31	0,27	0,24	0,22	0,18	-	-	-
20	-	1,14	-	1,21	1,07	0,95	1,49	1,25	2,03	1,81	1,63	1,48	0,37	0,32	0,29	0,26
25	-	2,19	-	1,88	1,65	1,47	2,31	1,94	3,15	2,8	2,52	2,3	0,85	0,74	0,66	0,59
32	-	-	6,61	-	-	5,16	4,23	3,59	5,52	4,93	4,45	4,06	1,72	1,50	1,33	1,20

(Unit: N-m)

Scostamento angolare

Anti-roll accuracy

Winkelabweichung

Ecartement angulaire

Desviación angular

Precisão angular anti-giro

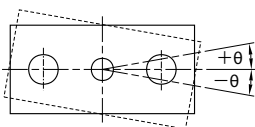

Ø	Scostamento angolare Anti-roll Accuracy Ecartement angulaire Winkelabweichung Desviación angular Precisão angular anti-giro
	θ
12	± 0,09°
16	± 0,08°
20	± 0,08°
25	± 0,07°
32	± 0,07°



Grafico per utilizzo come fermo

- Graph for the use as a stopper (Ø 12 ÷ 32)
- Diagramm für die Verwendung als STOPPER (R12 – 32)
- Graphique pour utiliser le vérin en tant que butée
- Gráfico para el uso como parado (Ø 12 ÷ 32)
- Gráfico para utilização como stopper (Ø 12 ÷ 32)

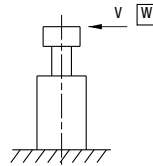

CAPACITÀ DI FERMO
 STOP CAPACITY
 STOPP KAPAZITÄT
 CAPACITE D'ARRÊT
 CAPACIDAD DE PARADA
 CAPACIDADE DE PARADA

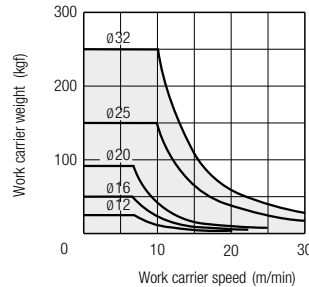

CARICO LATERALE
 LATERAL LOAD
 NORMALE SEITENKRAEFTE
 CHARGE LATÉRALE
 CARGA LATERAL
 CARGA LATERAL

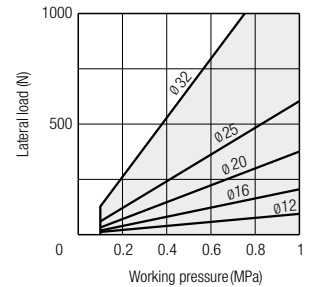

COEFFICIENTE DI CONVERSIONE
 COEFFICIENTS FOR CONVERSION
 UMRECHNUNGSKOEFFIZIENTEN
 COEFFICIENTS DE CONVERSION
 COEFFICIENTE DE CONVERSIÓN
 COEFICIENTE DE CONVERSÃO

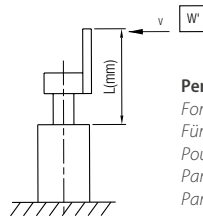

Per attaccare una piastra alla barra di collegamento, scegliere un diametro secondo la formula.

- For the use of attaching a plate to the link bar, choose a bore size referring to the formula.
- Für die Befestigung einer Platte an die Verbindungsstange, nehmen Sie für die Bohrdurchmesser Bezug auf die Formel
- Pour la fixation d'une plaque à la barre de liaison, choisissez un diamètre suivant la formule.
- Para la fijación de una placa sobre la barra, escoger un diámetro referido a la fórmula
- Para aplicações com placas fixadas no cilindro, escolha o diâmetro de acordo com a fórmula.

SERIES	Ø 12	Ø 16	Ø 20	Ø 25	Ø 32
ℓ	40	42	42	42	44

$$W^1 = \frac{W \cdot \ell}{L}$$

W: Peso massimo di lavoro come da grafico per la funzione di bloccaggio.

- W: The maximum weight of the working load in the above graph for the stopper's capacity.
- W: Höchstearbeitsgewicht gemäss Diagramm für die Verriegelungsfunktion
- W: Charge maximale de travail donnée dans le graphique ci dessus pour la fonction de verrouillage.
- W: Peso máximo para el trabajo realizado en el grafico superior para la capacidad de paro.
- W: Peso máximo da carga de trabalho no gráfico acima para a capacidade do stopper



Grafico utilizzo sollevamento

- Capacity graph for the use as a LIFTER
- Diagramm für die Verwendung als HEBER
- Graphique pour utilisation de levage
- Gráfico para el uso como elevador
- Gráfico para uso como Lifter (levantamento de cargas)

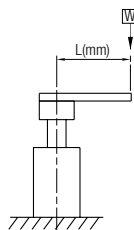

Carico di eccentricità consentito per uso sollevamento alla pressione di 5 bar. Mostra il valore consentito dinamico a L (mm) dal centro della guida.

- Allowable eccentricity load for the use as a lifter at supply pressure 5 bar. Show the dynamic allowable value at L (mm) from the centre of the guide rod.
- Zulässige Exzentrizitäts-Last für die Verwendung als Heber bei 5 bar Betriebsdruck. Zeigt den dynamisch zulässigen Wert bei L (mm) von der Mitte der Führungsstange
- Charge excentrée autorisée pour l'utilisation de levage à la pression de 5 bar. Montrez la valeur dynamique autorisée à L (mm) à partir du centre de guidage.
- Carga de excentricidad permitida para el uso como elevador a presión de 5 bar. Muestra el valor dinámico permisible a L (mm) desde el centro del eje de guía.
- Distância máxima da carga com relação ao centro do cilindro para aplicações como lifter com pressão de alimentação de 5 bar. Ver o valor permitido dinâmico em L (mm) a partir do centro da barra de guia.

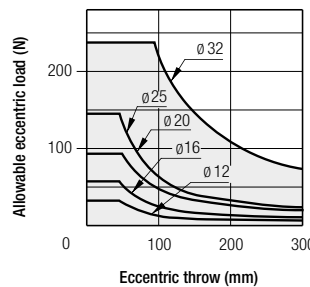

Cuscinetto scorrimento 10-50 st
 Slide Bearing 10-50 st
 Gleitlager 10-50 st
 Guide lisse 10-50 st
 Cojinete 10-50 st
 Deslizamento por esfera 10-50 st

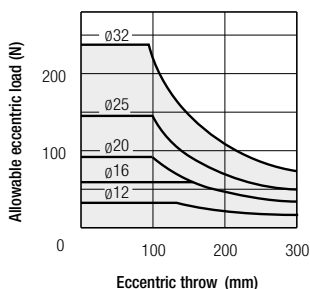

Cuscinetto scorrimento superiore a 51 st
 Slide Bearing over 51 st
 Gleitlager über 51 st
 Guide lisse au delà de 51 st
 Cojinete superior 51 st
 Deslizamento por esfera 51 st

SERIE CG02 - CILINDRI DOPPIO EFFETTO MAGNETICO GUIDATO

DOUBLE ACTING MAGNETIC DUAL-ROD CYLINDER
 ZYLINDER DOPPELTWIRKEND MAGNETISCH GEFÜHRT
 VÉRIN GUIDÉ DOUBLE EFFET MAGNÉTIQUE
 CILINDROS COMPACTOS GUIADOS DOBLE EFECTO MAGNÉTICO
 CILINDROS DUPLA AÇÃO MAGNÉTICO COM HASTE DUPLA



CARATTERISTICHE TECNICHE

TECHNICAL CHARACTERISTICS
 TECHNISCHE ANGABEN
 CARACTÉRISTIQUES TECHNIQUES
 CARACTERÍSTICAS TÉCNICAS
 CARACTERÍSTICAS TÉCNICAS



1907/2006
REACH

2011/65/CE
RoHS

Materiali	IT	Materials	GB	Materialien	DE
<ul style="list-style-type: none"> Corpo: Lega alluminio Piastra: Acciaio Stelo: Ø 12÷20 acciaio inox Ø 32 Acciaio Magnete: Plastroferrite Guarnizioni: NBR Ammortizzatore: NBR 		<ul style="list-style-type: none"> Body: Aluminum alloy Plate: Carbon Steel Piston rod: Ø 12÷20 Stainless steel Ø 32 Carbon Steel Magnet: Plastroferrite NBR seals Cushion: NBR 		<ul style="list-style-type: none"> Körper: Aluminium Legierung Platte: Stahl Kolbenstange: R̄ 12÷20 Edelstahl R̄ 32 Stahl Magnet: Plastroferrit Dichtungen: NBR Stossdämpfer: NBR 	
Matériaux	FR	Materiales	ES	Materiais	PT
<ul style="list-style-type: none"> Corps : Alliage d'aluminium Plaque : Acier Tige : Ø 12÷20 acier inox Ø 32 Acier Aimant : Plastroferrite Joints : NBR Amortissement : NBR 		<ul style="list-style-type: none"> Cuerpo: Aleación de aluminio Placa: Acero Vástago: Ø 12÷20 acero inox Ø 32 acero Magnete: Plastroferrita Juntas: NBR Amortiguación: NBR 		<ul style="list-style-type: none"> Corpo: Liga de alumínio Placa: Aço Haste: Ø 12÷20 aço inox Ø 32 aço Magnético: Plastroferrite Vedações: NBR Amortecimento: NBR 	



Pressioni

Pressures
 Druckbereich
 Pressions
 Presiones
 Pressões

Ø	6	12	16	20	25	32
bar min	1,5	1			0,5	
bar max			7			



Temperature

Temperatures
 Temperatures
 Temperatur
 Températures
 Temperaturas
 Temperaturas

-5 °C (No freezing)
 + 60 °C



Fluidi compatibili

Aria (Lubrificazione non necessaria).

Fluids
 Air (Lubrication not necessary).

Geeignete Medien
 Luft (Schmierung nicht erforderlich).

Fluides compatibles
 Air (Lubrification pas nécessaire).

Fluidos compatibles
 Aire (Lubrificación no necesaria).

Fluidos compatíveis
 Ar (Lubrificação não necessária).



Alesaggi

Bores
 Durchmesser
 Diamètres
 Diámetros
 Diâmetros

6-12-16-20-25-32 mm



Range velocità

Speed range
 Verfügbarer Geschwindigkeitsbereich
 Plage de vitesse disponible
 Rango velocidad
 Range de velocidades

Ø	6	12	16	20	25	32
	50÷300			50÷500		

(Unit: mm/sec)



Tipo di montaggio

Mounting Type

Montageart

Type de montage

Tipo de montaje

Tipo de montagem

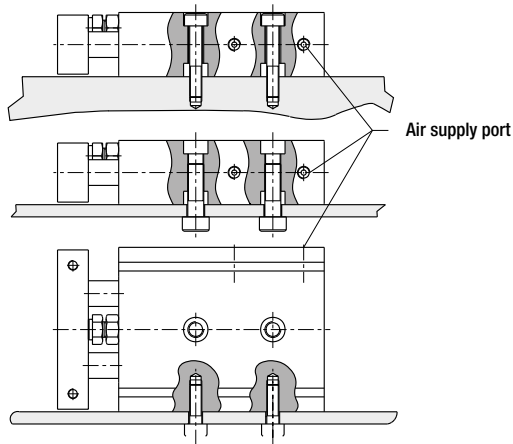

Sensori consigliati

Sensors recommended

Empfohlene Sensoren

Capteurs recommandés

Sensores recomendados

Sensores aconselhados

DC 01 RM8

DC 01 R2M

DC 03 PM8

DC 03 P2M

DC 04 PM8

DC 04 P2M



Scostamento angolare

Anti-roll accuracy

Winkelabweichung

Ecartement angulaire

Desviación angular

Precisão angular anti-giro

± 0,1°



Tabella dei codici di ordinazione

Ordering codes

Bestellschlüssel

Code de commande

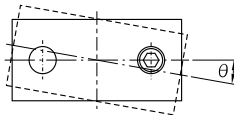
Tabla de codificación para pedidos

Tabela de codificação para compra

SERIE	Ø mm	Corsa Stroke Hub Course Carrera Curso mm
-------	---------	--

C G 0 2 **0 0 6** **0 0 1 0**

006
012
016
020
025
032

0010
0020
0030
0040
0050
0060
0070
0080
0090
0100

A richiesta corse intermedie o superiori.
Intermediate or higher strokes are available upon request.
Auf Anfrage Zwischenhübe.
Autres courses sur demande.
Bajo demanda carreras intermedias o superiores.
Cursos intermedíarios ou superiores sob encomenda.

Ø mm	Corse - Strokes - Hub - Courses - Carreras - Cursos mm									
	10	20	30	40	50	60	70	80	90	100
6	▲	▲	▲							
12	▲	▲	▲	▲	▲	▲	▲			
16	▲	▲	▲	▲	▲	▲	▲	▲	▲	▲
20	▲	▲	▲	▲	▲	▲	▲	▲	▲	▲
25	▲	▲	▲	▲	▲	▲	▲	▲	▲	▲
32	▲	▲	▲	▲	▲	▲	▲	▲	▲	▲

CG02 Ø 6 ÷ Ø 32

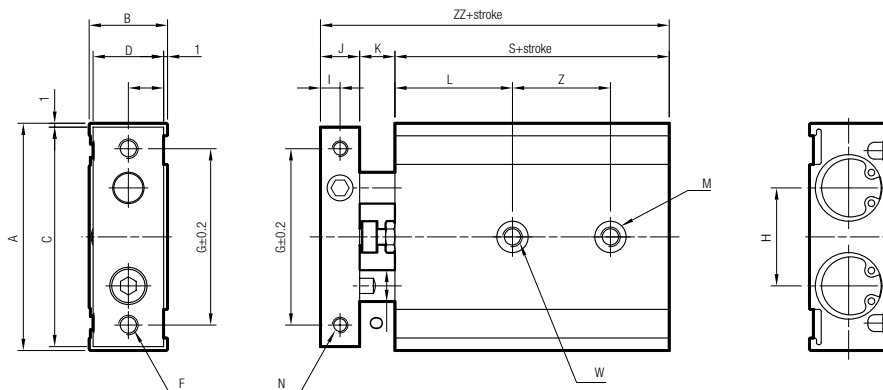

Ø 12 - 16

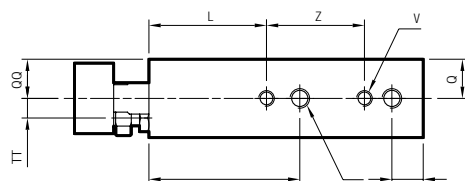

Ø 20 ÷ 32

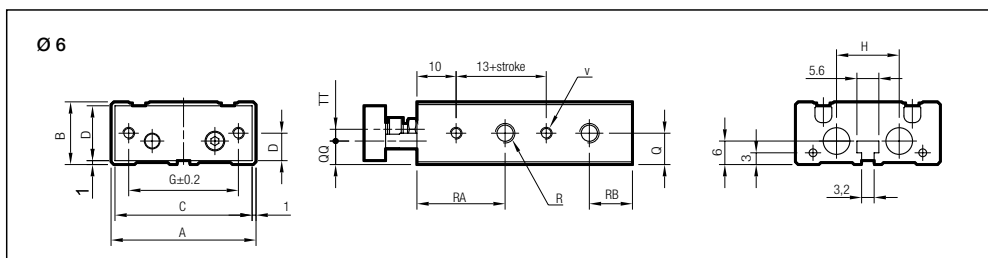
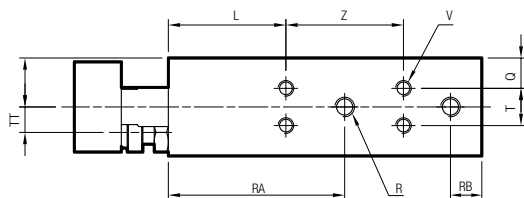

Ø	A	B	C	D	E	F (Thru)	G	H	I	J	K	L	M (both side)	N (both side)	O	Q	QQ	R (both side)
6	37	16	35	14	7	2-M3x0,5	28	16	2,75	5,5	8	13	2-Ø6,5x3,3*	2-M3x0,5	4	8	6	4-M5x0,8
12	46	18	44	16	8	2-M4x0,7	35	19	4	8	9	20	4-Ø6,5x3,3	4-M3x0,5x5	6	9	10	4-M5x0,8
16	58	20	56	18	9	2-M5x0,8	45	25	5	10	9	30	4-Ø8x4,4	4-M4x0,7x6	8	10	10	4-M5x0,8
20	64	25	62	23	11,5	2-M5x0,8	50	28	6	12	12	30	4-Ø9,5x5,3	4-M4x0,7x6	10	7,75	12,5	4-M5x0,8
25	80	30	78	28	14	2-M6x1,0	60	35	6	12	12	30	4-Ø11x6,3	4-M5x0,8x8	12	8,5	15	4-G1/8
32	98	38	96	36	18	2-M6x1,0	75	44	8	16	14	30	4-Ø11x6,3	4-M5x0,8x8	16	9	19	4-G1/8

Ø	RA	RB	S	T	TT	V (both side)	W (Thru)	Z (stroke)				ZZ
								10-15-20-25	30-35-40-45-50	60-70-75	80 90-100	
6	22,5	11	45	-	3	4-M3x0,5x4,5	2-Ø3,4	10+1/2 Stroke**				58,8
12	30	8	55	-	3,5	4-M3x0,5x4,5	2-M4x0,7	30	40	50	-	72
16	38,5	8	60	-	5	4-M4x0,7x5	2-M5x0,8	25	35	45	55	79
20	45	8	70	9,5	6,5	8-M4x0,7x5,5	2-M6x1,0	30	40	60		94
25	46	9	72	13	9	8-M5x0,8x7,5	2-M8x1,25	30	40	60		96
32	56	10	82	20	11,5	8-M5x0,8x7,5	2-M8x1,25	40	50	70		112

* Ø 6 - solo da un lato
 Ø 6 - single side
 Ø 6 - Einseitig
 Ø 6 - un seul coté
 Ø 6 - solo de un lado
 Ø 6 - somente de um lado

** Ø 6 - corsa (10-20-30)
 Ø 6 - stroke (10-20-30)
 Ø 6 - Hub (10-20-30)
 Ø 6 - course (10-20-30)
 Ø 6 - carrera (10-20-30)
 Ø 6 - curso (10-20-30)

FORZE E CONSUMI

FORCES AND CONSUMPTIONS

KRÄFTE UND LUFTVERBRAUCH

FORCES ET CONSOMMATIONS D'AIR

FUERZAS Y CONSUMOS

FORÇAS E CONSUMOS

Forze di spinta e tiro - Thrust and traction forces - Schub-und zugkräfte - Force de poussée et de traction - Fuerza de empuje y tracción - Força de avanço e recuo.

Ø Cilindro Cylinder Zylinder Vérins Cilindro Cilindro	Ø Stelo Rod Stange Tige Vástago Haste	Superficie spinta Pushing surface Schubfläche Surface de poussée Superficie de empuje Área de avanço	Superficie trazione Traction surface Zugfläche Surface de traction Superficie de tracción Área de retorno	Pressione di lavoro Operating pressure Betriebsdruck Pression de service Presión de trabajo Pressão de operação									
				bar									
mm	mm	mm ²	mm ²	1	2	3	4	5	6	7	8	9	10
				Forza sviluppata Output force Zylinderkraft Force du vérin Fuerza desarrollada Força desenvolvida N									
6	4	56,52	31,40	S = 5,00 T = 2,80	10,00 5,50	15,00 8,30	20,00 11,00	25,00 13,90	29,90 16,60	34,90 19,40	39,90 22,20	44,90 25,00	49,90 27,70
12	6	226,08	169,56	S = 20,00 T = 15,00	40,00 30,00	60,00 45,00	80,00 60,00	100,00 75,00	119,80 89,80	139,80 104,80	159,60 119,80	179,60 134,80	199,60 149,80
16	8	401,92	301,44	S = 35,40 T = 26,60	71,00 53,20	106,00 79,80	142,00 106,40	177,40 133,00	213,00 159,60	248,00 186,00	283,80 213,00	319,40 239,40	354,80 266,00
20	10	628,00	471,00	S = 55,40 T = 41,60	110,80 83,20	166,20 124,80	221,80 166,40	277,20 208,00	332,60 249,60	388,00 291,00	443,60 332,60	499,00 374,20	554,46 415,80
25	12	981,25	755,17	S = 86,60 T = 66,60	173,20 133,40	260,00 200,00	346,60 266,60	433,20 333,40	519,80 400,00	606,40 466,60	693,00 533,40	779,60 600,00	866,20 666,80
32	16	1607,68	1205,76	S = 142,00 T = 106,40	283,80 213,00	425,80 319,40	567,60 425,80	709,80 532,20	851,60 638,80	993,60 745,20	1135,60 851,60	1277,40 958,00	1419,40 1064,40

S : Spinta
 Thrust
 Schub
 Poussée
 Empuje
 Avanço

T : Trazione
 Traction
 Zugkraft
 Tracción
 Tracción
 Recuo

Consumi cilindro - Cylinder air consumption - Zylinder Luftverbrauch - Consommation d'air des vérins - Consumo cilindro - Consumo de ar do cilindro.

Ø Cilindro Cylinder Zylinder Vérins Cilindro Cilindro	Ø Stelo Rod Stange Tige Vástago Haste	Superficie spinta Pushing surface Schubfläche Surface de poussée Superficie de empuje Área de avanço	Superficie trazione Traction surface Zugfläche Surface de traction Superficie de tracción Área de retorno	Pressione di lavoro Operating pressure Betriebsdruck Pression de service Presión de trabajo Pressão de operação									
				bar									
mm	mm	mm ²	mm ²	1	2	3	4	5	6	7	8	9	10
				Consumo aria per ogni 10 mm di corsa Air consumption for each 10 mm of stroke Luftverbrauch pro 10 mm Hub Consommation d'air par 10 mm de course Consumo aire para cada 10 mm de carrera Consumo de ar para cada 10 mm de curso NL									
6	4	56,52	31,40	S = 0,0011 T = 0,0006	0,0023 0,0013	0,0034 0,0019	0,0045 0,0025	0,0057 0,0031	0,0068 0,0038	0,0079 0,0044	0,0090 0,0050	0,0102 0,0057	0,0113 0,0063
12	6	226,08	169,56	S = 0,0045 T = 0,0034	0,0090 0,0068	0,0136 0,0102	0,0181 0,0136	0,0226 0,0170	0,0271 0,0203	0,0317 0,0237	0,0362 0,0271	0,0407 0,0305	0,0452 0,0339
16	8	401,92	301,44	S = 0,0080 T = 0,0060	0,0161 0,0121	0,0241 0,0181	0,0322 0,0241	0,0402 0,0301	0,0482 0,0362	0,0563 0,0422	0,0643 0,0482	0,0723 0,0543	0,0804 0,0603
20	10	628,00	471,00	S = 0,0126 T = 0,0094	0,0251 0,0188	0,0377 0,0283	0,0502 0,0377	0,0628 0,0471	0,0754 0,0565	0,0879 0,0659	0,1005 0,0754	0,1130 0,0848	0,1256 0,0942
25	12	981,25	755,17	S = 0,0196 T = 0,0151	0,0393 0,0302	0,0589 0,0453	0,0785 0,0604	0,0981 0,0755	0,1178 0,0906	0,1374 0,1057	0,1570 0,1208	0,1766 0,1359	0,1963 0,1510
32	16	1607,68	1205,76	S = 0,0322 T = 0,0241	0,0643 0,0482	0,0965 0,0723	0,1286 0,0965	0,1608 0,1206	0,1929 0,1447	0,2251 0,1688	0,2572 0,1929	0,2894 0,2170	0,3215 0,2412

S : Spinta
 Thrust
 Schub
 Poussée
 Empuje
 Avanço

T : Trazione
 Traction
 Zugkraft
 Tracción
 Tracción
 Recuo



Aignep si riserva il diritto di variare modelli e ingombri senza preavviso.
Aignep reserves the right to vary models and dimensions without notice.
Aignep behält sich das Recht vor, Daten ohne Ankündigung zu ändern.
Aignep se réserve le droit de modifier les données sans préavis.
Aignep reserva-se o direito de alterar os modelos e dimensões sem prévio aviso.

Aggiornamento - Updated - Stand - Mise à jour - Actualización - Atualização: 11/2018



AIGNEP SPA
Via Don G. Bazzoli - 34
25070 Bione (BS)
ITALY

T: +39 0365 896626
F: +39 0365 896561

aignep.it@aignep.com



AIGNEP IBERICA SA
Pol. Ind. el Tortuguer "Can Prat"
Naves 23 y 24 08691
Monistrol de Montserrat - Barcelona
SPAIN

T: +34 93 828 47 36
F: +34 93 828 44 32

aignep.es@aignep.com



**AIGNEP DO BRASIL COMERCIO DE
COMPONENTES PARA AUTOMAÇÃO LTDA**
Rua Campos Mello, 185
Vila Mathias - 11015-011 - Santos/SP
BRASIL

T: +55 13 2138 4049
F: +55 13 2138 4052

aignep.br@aignep.com



AIGNEP USA LLC
7121 Loblolly Pine Blvd
Fairview, TN 37062
U.S.A.

T: +1 615 771 6650
F: +1 615 771 0926

aignep.usa@aignep.com



AIGNEP AG
Industriestrasse 22A
2545 Selzach
SWITZERLAND

T: +41 32 342 09 09
F: +41 32 342 09 11

aignep.ch@aignep.com



AIGNEP FRANCE SARL
2, Avenue des Améthystes
44338 Nantes Cedex 3
FRANCE

T: +33 02 72 24 26 50
F: +33 02 72 24 26 51

aignep.fr@aignep.com



AIGNEP LATAM
Sede:
Calle 15 N 27-78 Local 2
Sec. Paloquemao - 111411
Bogota
COLOMBIA

T: +57 1 37 52 50 1
T: +57 1 37 52 50 8

Sucursal:
Calle 6 SUR 52-80 Local 19
Cc. El Rodeo - 0520024 Medellin
COLOMBIA

T: +57 4 58 70 90 1

aignep.latam@aignep.com



**AIGNEP (Wuxi) FLUID
TECHNOLOGY CO., LT D.**
NO 8, Yanggong Road, Nanhu Main Road
Wuxi, Jiangsu.
CHINA

T: 0510-8544 1923
F: 0510-8540 0223

aignep.cn@aignep.com

www.aignep.com